



## **Diade Series Weighing Terminals**



*Touch screen,  
a thousand data items at your fingertips*

*The DD 1010i Indicator  
Integration and Efficiency at a TOUCH*



In Pythagorean mathematics, DIADE indicates two elements that, when combined, produce excellence. The DIADE Series terminals use the same principle to combine computer programming power and flexibility together with the measuring requirements of a weighing instrument.



# DIADE

The DIADE Series is a revolutionary new range of fully programmable weighing terminals. In addition to being high performance weighing instruments, these terminals offer exciting and innovative opportunities for application specific customization.

The DIADE Series not only provides tailor-made software for specific operations, but it can also be independently programmed to meet all the various application needs when used in an industrial environment -all thanks to the powerful modular SCALECORE software and SCALEWIZARD development tool .

The very same system offers almost endless programming possibilities, using state-of-the-art languages, for the management of complex applications, together with versatile PLC software to manage these processes more simply.

### APPLICATIONS

Because of its extreme versatility the DIADE Series can be used in all industrial weighing environments. The family of Diade weighing terminals is undoubtedly the perfect solution for many control processes, making possible a significant reduction in the system components used, with the following benefits:

- Fewer and less complex connections with a consequent reduction in installation costs
- Reduced costs for system components
- Simpler maintenance/assistance procedures

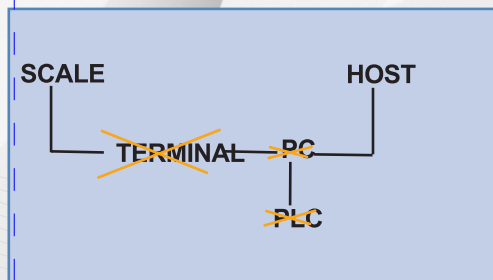

A solution with traditional terminals



Terminal DD1050 solution

## CHOOSE FROM OUR RANGE OF SOFTWARE OPTIONS TO CREATE "YOUR" VERY OWN DIADE

### SCALECORE

Is a set of software components for the independent development of applications for industrial weighing, making it much easier to create modular structures, to manage data and graphics and facilitate communication between distributed modules.

The main components supplied are:

- Graphics engine
- Graphics libraries
- Scale management
- Distributed peripherals management
- Communication protocols
- Print driver
- Real time PLC processing software
- Server Database

All these tools make it possible to totally personalise the system functions, for example:

- To adapt the operator interface
- To modify the database structure
- To modify the functioning logic

### SCALEWIZARD

Is a piece of PC software that allows the DIADE Series terminal to be managed via a personal computer.

The principal basic functions include:

- Display generation/personalisation
- Archive building
- Print personalisation
- Instrument configuration
- Applications up-load
- Back-up



### SOFTWARE (OPTIONS)

DIADE Series terminals are equipped with weight measuring software.

It is also possible to use this instrument with software designed for a diverse number of applications. VEHICLE WEIGHING packages are available that can be connected directly to a wide range of management systems for the export/import of data. In addition to calculating net weight, it is also possible to manage the additional data required for printing transport documentation, including A4 printed format. The system can also be used to manage identification and access control equipment, such as card readers, electronic barriers, automatic number plate recognition systems, traffic lights etc.

BATCH CONTROL software is available for weighing systems to control and manage weighing cycles, recipe formulae, silos, products, statistics, fast and slow filling and emptying plus automatic in-flight correction.

WASTE & RECYCLING MANAGEMENT software for waste processing sites, software for LOGISTICS, FILLING/EMPTYING operations and for FOOD INDUSTRY processing operations are also available.



**B** 3,260 kg **W2**

Paper	Plastic	Aluminium	Glass	Oil	Organic
Wood	Steel	Build. Mat.	Batteries	Medicines	Clothes
Gardening	Metal	Furniture	Fridges	Accumulators	CFC

Keyboard Next

Select waste type 29-4-2009 06:23 PM

**B** 3,260 kg **W2**

1st Weight 2nd Weight

Date	Id Plate	1st Weight	Date	2nd Weight	Net	Product
10-04-	AH234CF	10.350 kg	10-04-	35.460 kg	25.110 kg	Barbabietole
10-04-	BH435GF	9.590 kg	10-04-	28540 kg	18.950 kg	Mais
10-04-	TT543DF	11.340 kg				Grano
10-04-	HG345HF	10.450 kg				Barbabietole
10-04-	3H456DD	10.430 kg				Barbabietole
10-04-	AS345FF	11.520 kg				Grano Saraceno
10-04-	AD567FG	9.810 kg				Mais
10-04-	ER453GG	10.020 kg				Misto
10-04-	TT123DS	9.960 kg				Riso
10-04-	AS543FD	6.530 kg				Grano
10-04-	AA432GG	11.540 kg				Barbabietole
10-04-	AG322DD	10.050 kg				Grano Saraceno
10-04-	A358FF	11.050 kg				Barbabietole
10-04-	BC341EE	10.240 kg				Misto
10-04-	AI453BB	9.670 kg				Misto

Back Truck Trailer Delete Print modify Config Next

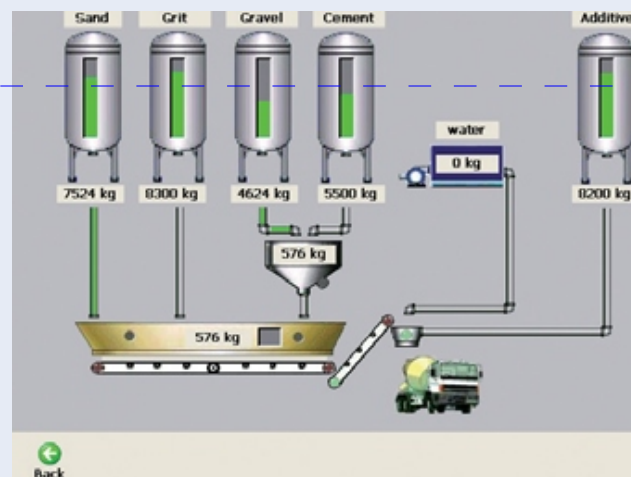



**SCALES & SOFTWARE (K) LTD**

INDUSTRIAL SCALES | RETAIL SCALES | HANGING SCALES | WEIGHBRIDGES | WEIGHING SOFTWARE

**DD 1050**

CREATE YOUR

OWN

**DIADE**

WITH CUSTOM GRAPHICS



### TECHNICAL SPECIFICATIONS

- 500 MHz processor
- 128 MB ram
- 128 MB flash memory
- 10.4" colour display with touch screen
- Ethernet 10/100 output
- WIFI connection option
- 2 off 24V AC/DC I/O
- 1 memory card and SD card expansion slot
- 3 expansion slots (for weighing machines, serial port, I/O, field buses etc).
- 12 VDC power supply, 110-230 VAC with external power supply.
- CE approved up to 6000 divisions-Multi-division and Multi-range versions (3x3000 or 2x4000)
- OIML certification
- NTEP approved

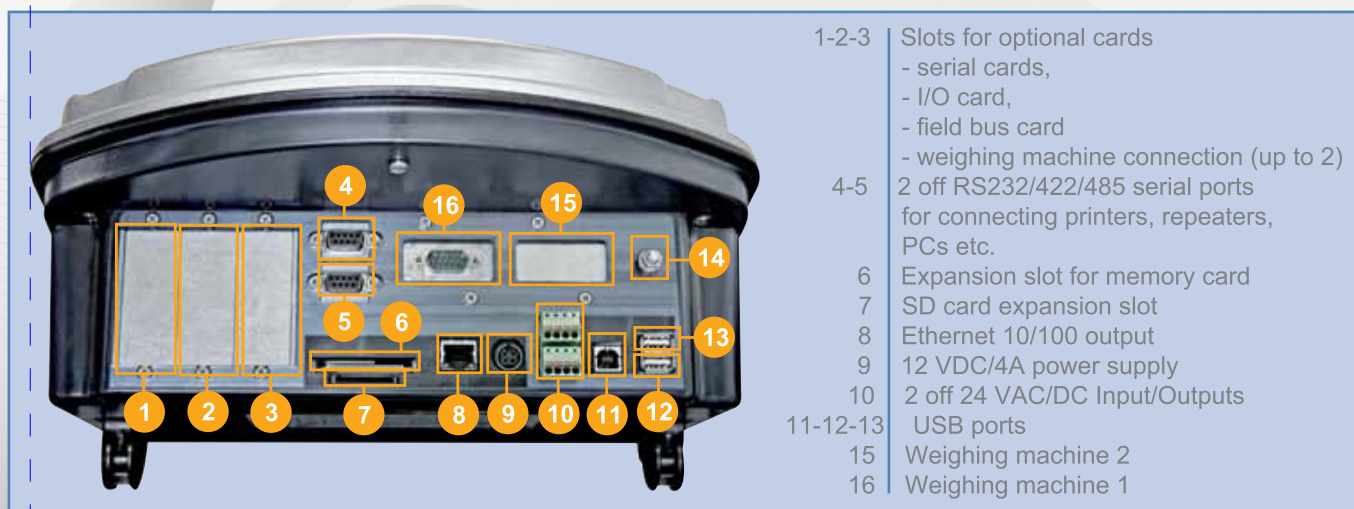

- 1-2-3 Slots for optional cards
  - serial cards,
  - I/O card,
  - field bus card
  - weighing machine connection (up to 2)
- 4-5 2 off RS232/422/485 serial ports for connecting printers, repeaters, PCs etc.
- 6 Expansion slot for memory card
- 7 SD card expansion slot
- 8 Ethernet 10/100 output
- 9 12 VDC/4A power supply
- 10 2 off 24 VAC/DC Input/Outputs
- 11-12-13 USB ports
- 15 Weighing machine 2
- 16 Weighing machine 1

### OPTIONAL EXTRAS

#### SERIAL OUTPUT CARD

A card that makes it possible to manage two extra serial outputs in addition to the two already provided

- RS232, RS422 and RS485 formats
- Programmable Baud Rate

#### INPUT/OUTPUT CARD

- Each card provides 4 inputs and 6 outputs in addition to those already provided with the standard terminal
- Input: Vmax. 24 VDC optical isolation
- Output: Optomos Vmax 24 VAC/DC, Imax 190 mA

#### PROFIBUS CONNECTION CARD

Profibus network connection card

- Profibus DP functionality
- Galvanic isolation
- Data rate from 9.6 kbit/s to 12 Mbit/s

#### WIFI COMMUNICATIONS DEVICE

802.11 wireless data transmission device

#### AUDIO CARD

- 2x10 W mono/stereo audio outputs
- Microphone input

#### DIGITAL/INPUT/ANALOGUE/OUTPUT CARD

Optional multifunctional card - particularly useful for process control

- 1 0-10 V / 4-20mA analogue output
- 2 Fmax. 2 kHz pulse counter inputs
- 1 0-10 V / 4-20 mA analogue input

#### WEIGHING MACHINE INTERFACE CARD

Analogue:

- Internal resolution up to one million points
- Conversion speed up to 100 readings per second
- 10 VDC load cell power supply
- Configurable digital filters Digital:
- RS485 interface with dedicated protocol
- Digital loadcell diagnostic management system (conversion, power, temperature etc.)
- Correction software for eccentric loads
- 0-18 VDC power cell, varies automatically according to the cable length



### Diade Model DD 1050 WEIGHING TERMINAL

The DD 1050 terminal is designed for industrial applications features the standard measuring software required for weighing management. To complete the terminal, various specific items of software are available for different weighing applications.

This eclectic design is reinforced by the SCALECORE software and the SCALEWIZARD development tool which make it possible to program the system completely independently within the WINDOWS CE environment.

### FEATURES AND PRINCIPLES

#### ROBUST AND VERSATILE:

Designed for industrial applications; body in ABS with a stainless steel front. Available in both bench and wall-mounted versions.

#### SUITABLE FOR ANY OPERATING ENVIRONMENT:

For applications in "harsh and aggressive" environments, the completely stainless steel version is available with IP68 protection.

#### FAST AND SIMPLE TO USE:

The 10.4" colour "TOUCH SCREEN" colour display features easy-to-understand icon graphics and the screen layout can be readily personalized for specific applications.

#### MAXIMUM APPLICATION FLEXIBILITY:

DIADE Series terminals are equipped with measuring software for managing weighing. Optional applications software makes it possible for users to personalise all the functions and graphics they need for their own operations. Even more proof of the system's extreme flexibility is provided by the ability to connect up to 4 weighing machines with either digital or analogue loadcells.

#### TOTAL PROGRAMMABILITY:

The SCALECORE set of software components allows the applications used in industrial weighing environments to be developed independently. This creates a versatile modular structure with personalised graphics and the ability to manage at will the data and communications required to run the weighing equipment connected to the system.

#### NETWORKED COMMUNICATIONS:

The hardware configuration, together with the programming power of the DD 1050 terminal, ensures simple connectivity with customers' own networks and because it is possible to install drivers for various peripheral accessories, such as printers etc., these can be managed directly from the terminal.

#### DATA MANAGEMENT:

By using an SQL relational database, enhanced with remote connectivity options and flexible archive structuring, targeted data management can be achieved enabling the data in question to be easily exported to corporate databases.

#### MANAGEMENT FROM A PERSONAL COMPUTER:

SCALEWIZARD is the PC software that makes it possible to manage the terminal with a personalised display, print-outs and archives.

# IT WEIGHS, MANAGES AND COMMUNICATES



## DD 1050

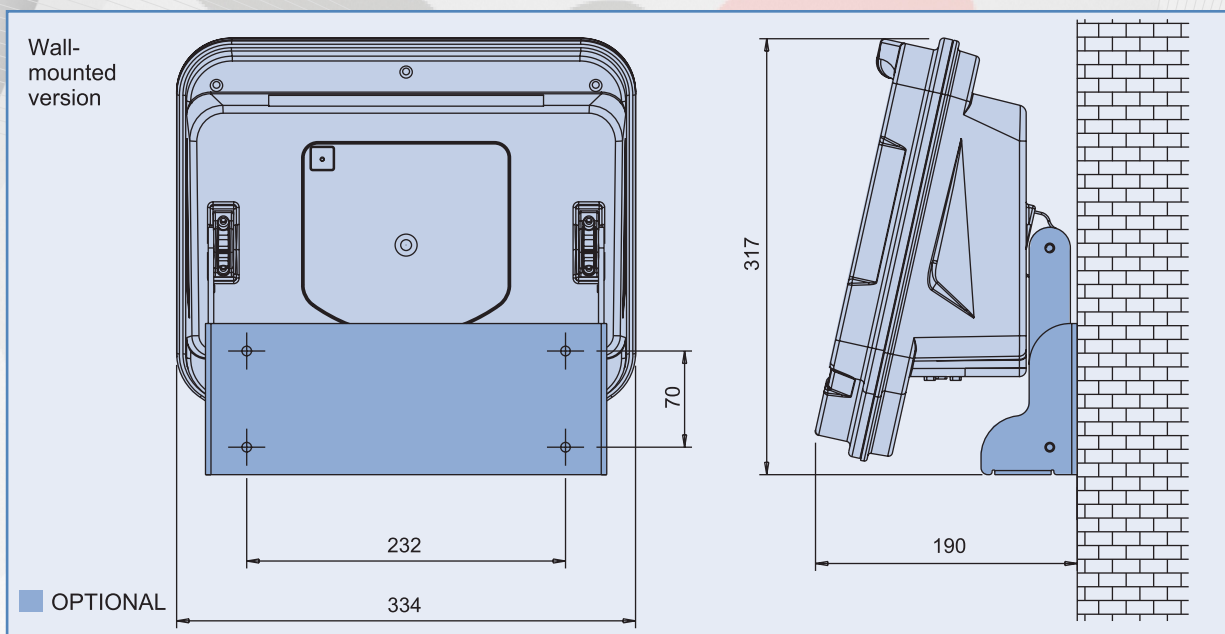
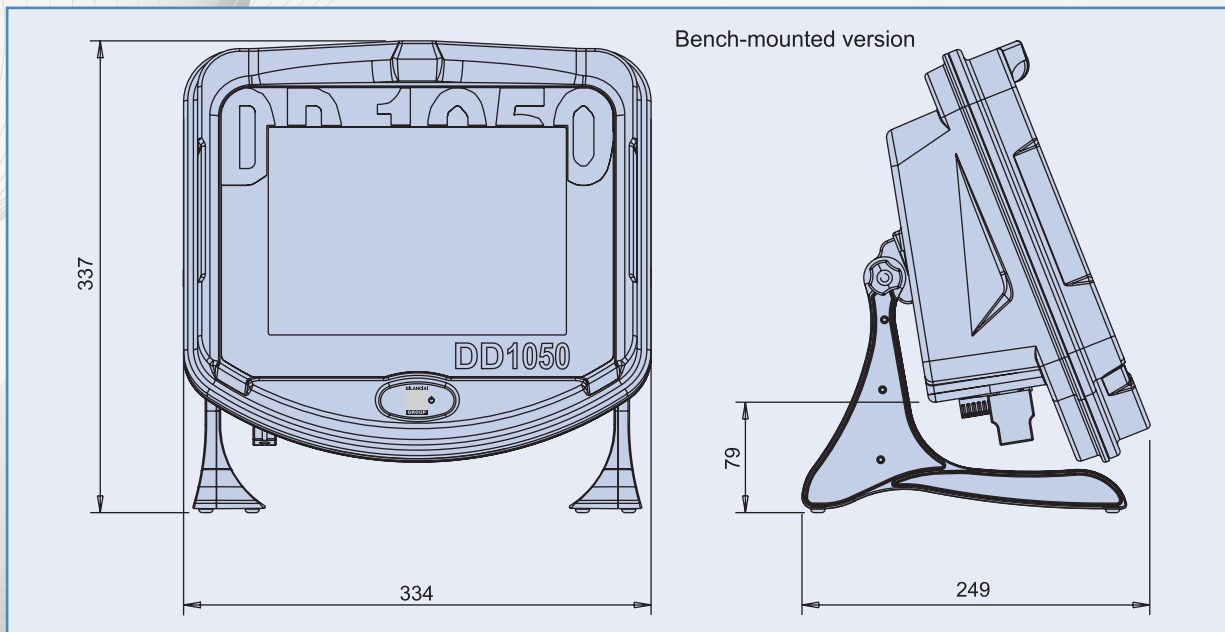

### Head Office:

The Filing Room (Ground Floor)  
Near Panari Hotel  
P.O Box 6863 -00200  
Tel: +020-2013976  
Mobile: 0722-303505  
0738-829064

### Eldoret Office:

KFA Building  
Opp Uchumi Supermarket  
Tel: 053 2032561  
Fax: 053 2063738  
Mobile: 0733-781832

info@scale-software.co.ke  
www.scale-software.co.ke